

LE PROCESS DE L'EAU

Aqualians

Etudes • Installations • Contrôles • Maintenance et Réparations



contact@aqualians.fr
www.aqualians.fr

| INDICE | CREATION | MODIFICATION | DATE | JPA DESSINE | VERIFIE | APPROUVE |
|--------|----------|--------------|------|----------------|---------|----------|
| | | | | | | |
| | | | | | | |
| | | | | | | |
| | | | | | | |
| | | | | | | |
| | | | | | | |
| | | | | | | |
| | | | | | | |
| | | | | | | |
| | | | | | | |
| | | | | | | |
| | | | | | | |
| | | | | | | |
| | | | | | | |
| | | | | | | |
| | | | | | | |
| | | | | | | |
| | | | | | | |
| | | | | | | |

AQUALIANS
209 RUE ARISTIDE BERGES
LA RAVOIRE 73490

DESSINE: JPA
VERIFIE: JMGC
DATE DE CREATION: 12/09/2019
AFFAIRE N°: 0479264354

COMMUNES DE CLAVANS
BESSE ET MIZOEN
SYNDICAT D'ASSAINISSEMENT DU CANTON DE L'OSANS

POSTE DE RELEVAGE EAUX USEES
PR3 PONT MOULIN

DOSSIER N°: **SEPTEMBRE 2019** 1/17

Liste des folios

| Type de document | Folio | Désignation |
|--------------------------|--------|--------------------------------------|
| Page de garde de dossier | 1 PAGE | |
| Sommaire | 2 A | Sommaire |
| Schémas | 3 | DEPARTS GENERAUX PUISSANCE |
| Schémas | 4 | DEPARTS GENERAUX PUISSANCE |
| Schémas | 5 | DEPART RELEVAGE POMPE 1 PUISSANCE |
| Schémas | 6 | DEPART RELEVAGE POMPE 2 PUISSANCE |
| Schémas | 7 | COMMANDE GENERALE |
| Schémas | 8 | COMMANDE POMPAGE |
| Schémas | 9 | SIGNALISATION |
| Schémas | 10 | RESERVE |
| Schémas | 11 | SOFREL S550 GENERALITES |
| Schémas | 12 | CARTE GSM 3G |
| Schémas | 13 | CARTE 8DI N°2 S550 |
| Schémas | 14 | CARTE 2AI N°3 S550 |
| Schémas | 15 | CARTE 4DO N°4 S550 |
| Carnet de câbles | 1 | -W1, -W2, -W3, -W7 |
| Carnet de câbles | 2 | -W7, -W20 |
| | | |
| | | |
| | | |
| | | |
| | | |
| | | |
| | | |
| | | |
| | | |
| | | |
| | | |

TARIF BLEU

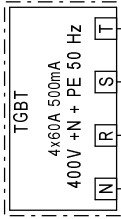

REPARTITEUR 3Ph+N

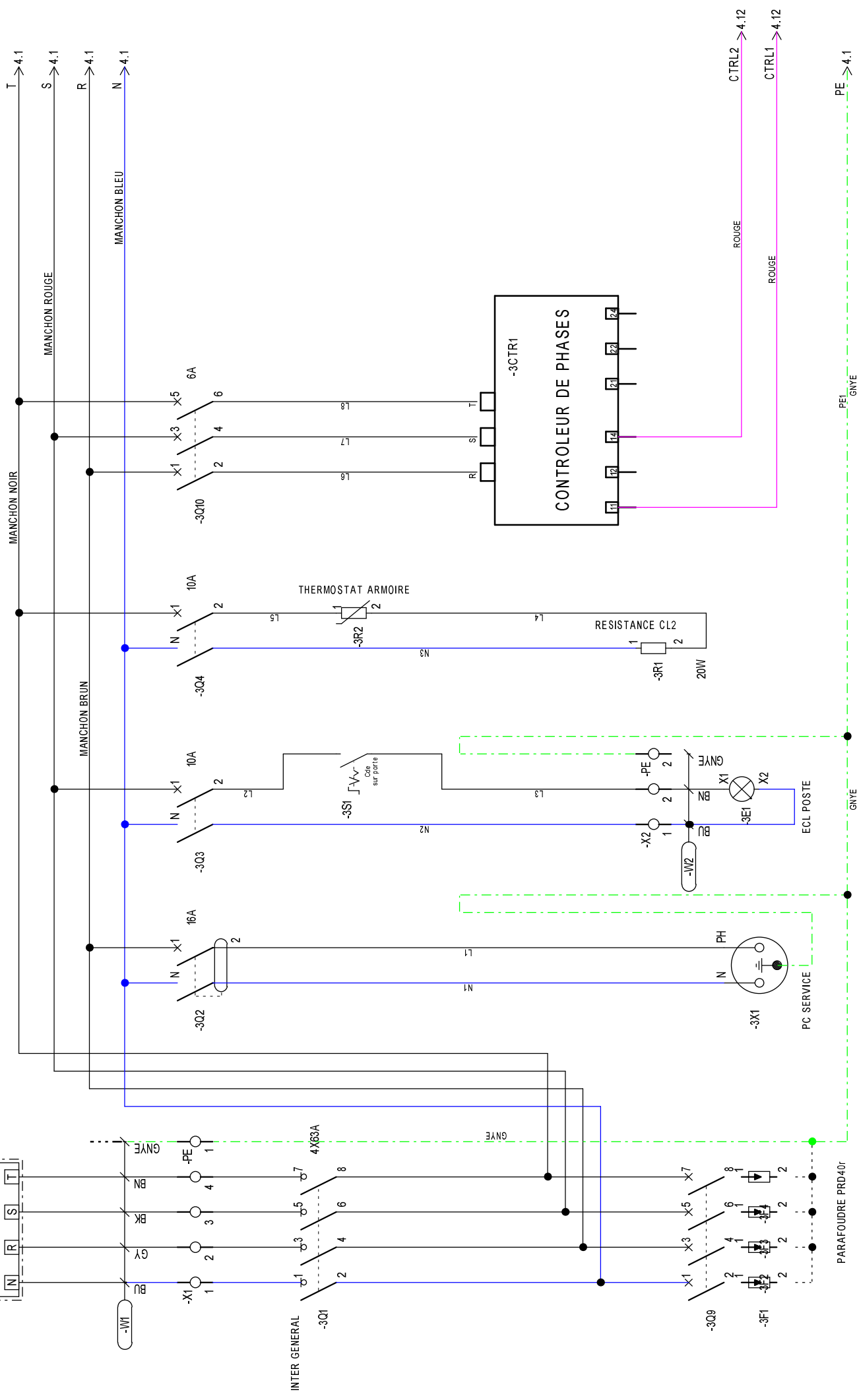

+ARM



| | |
|----------------|--------------|
| ESSE: | PA |
| VERIF: | JMC |
| DATE/CREATION: | MODIFICATION |
| NOCE: | DATE |
| | PA |
| | USA |

COMMUNES DE CLAVANS
 Dossier n° : SEPTEMBRE 2019

POSTE DE RELEVAGE EAUX USEES
 DEPARTS GENERAUX
 PUISSANCE

REPARTITEUR 3Ph+N

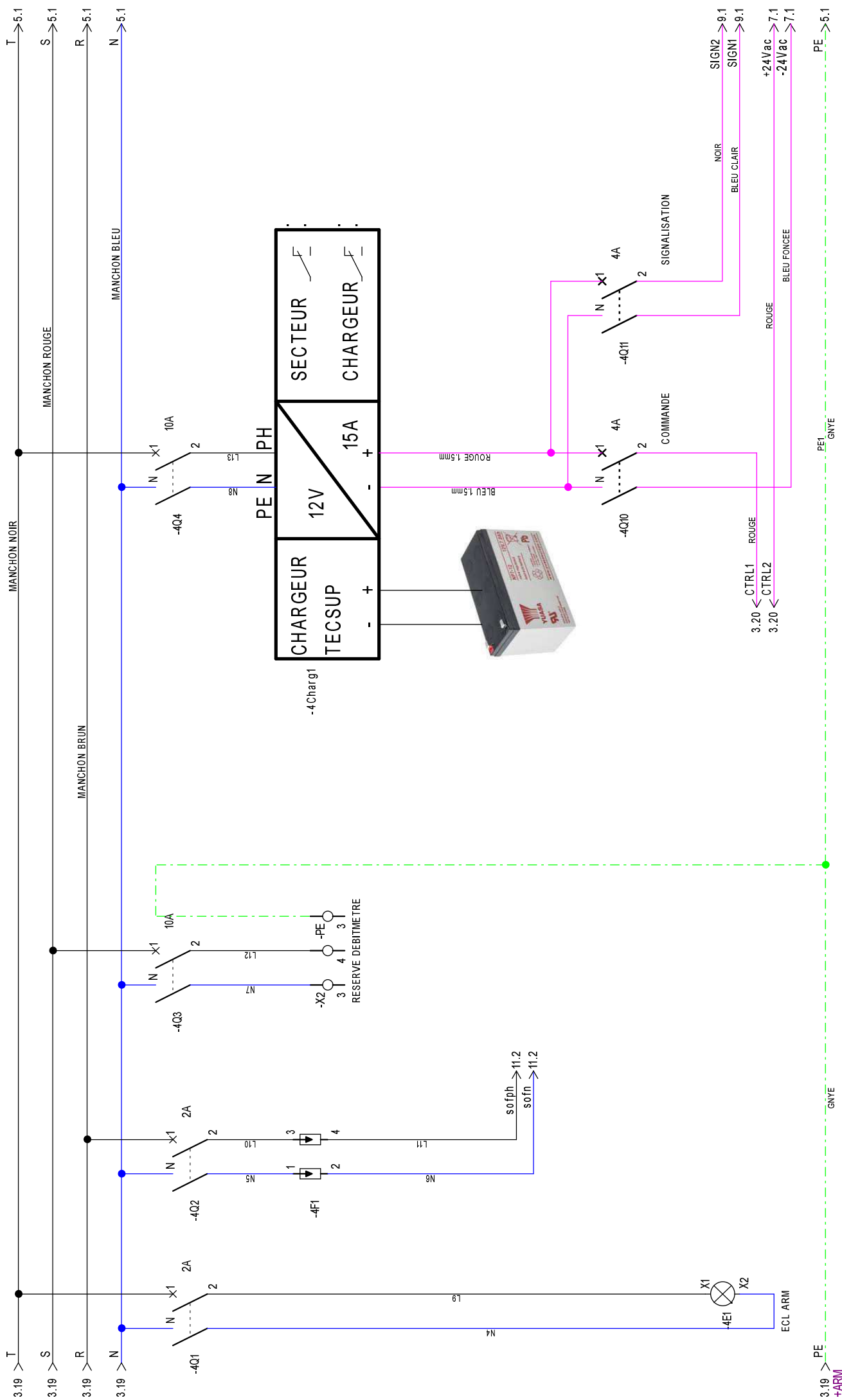

| | |
|---------------|------------|
| ESSE: | PA |
| VERIF: | JMCC |
| DATE DEGRAND: | 21/05/2019 |
| NOCE | |
| DATE | 11/03/2019 |
| CREATION | |
| MODIFICATION | |
| USA | |

COMMUNES DE CLAVANS
 Dossier n° : SEPTEMBRE 2019

POSTE DE RELEVAGE EAUX USEES
 DEPARTS GENERAUX
 PUISSANCE

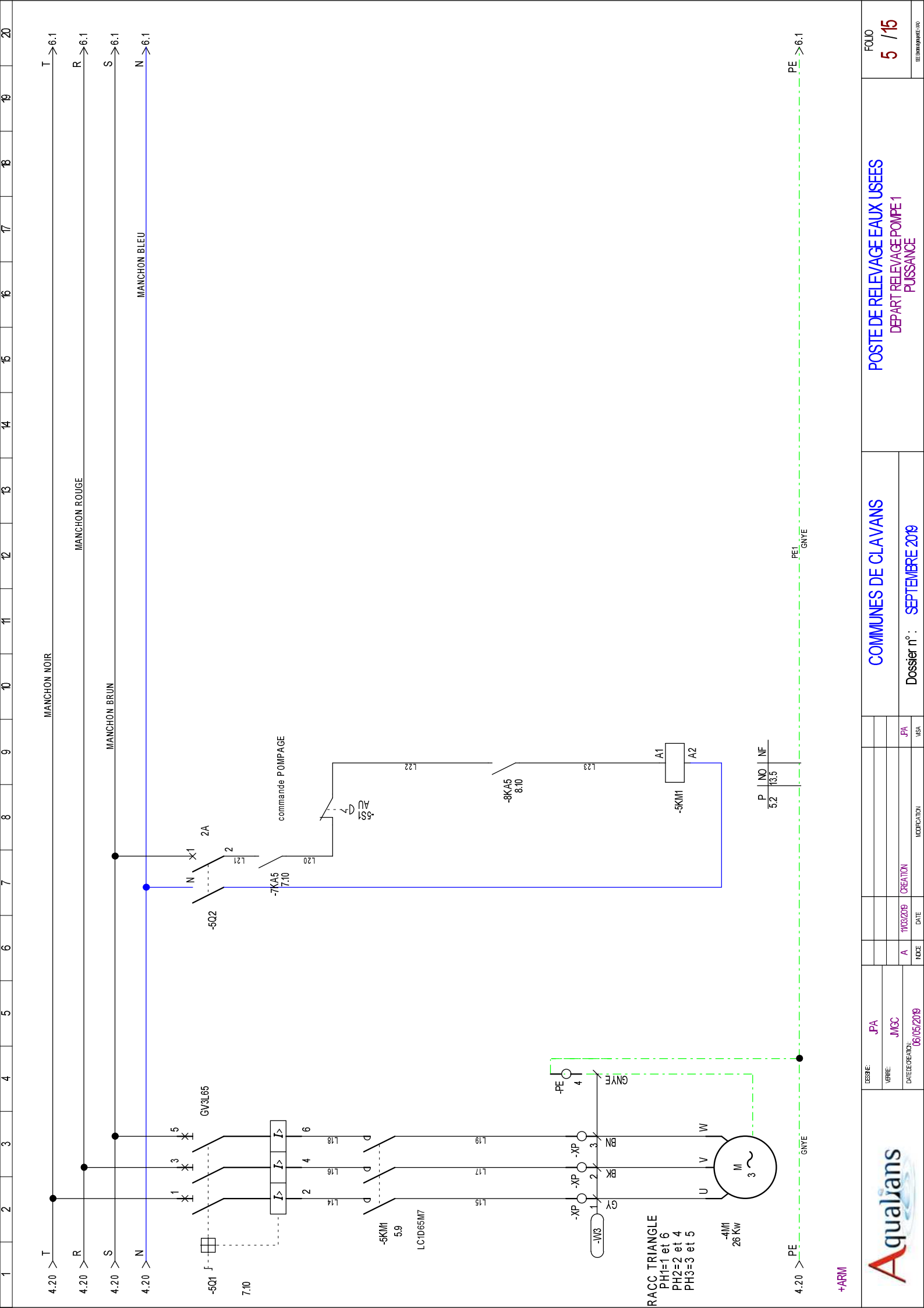

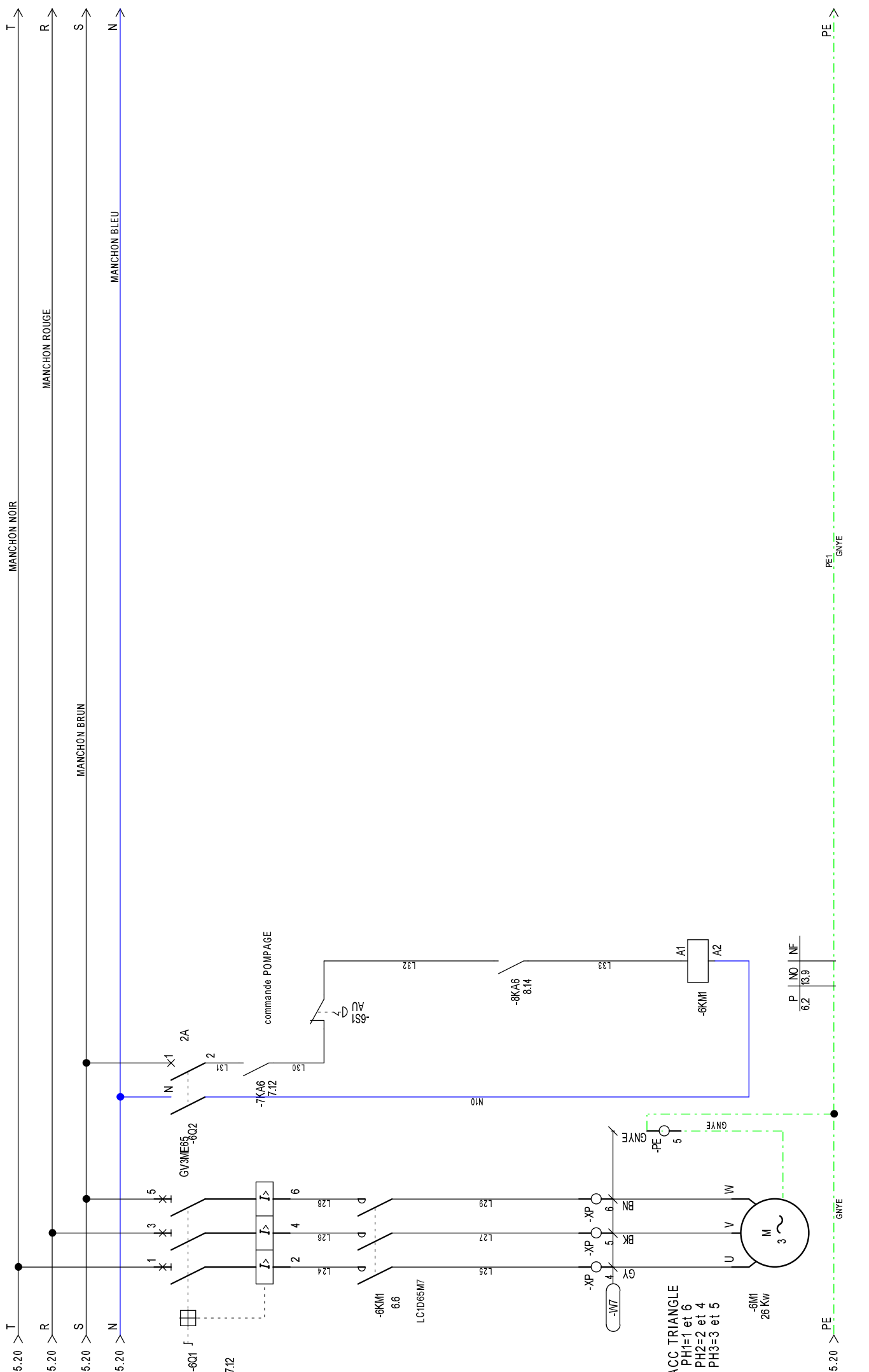

+ARM



| | |
|-------------|------------|
| ESRUE: | PA |
| VERIFIE: | JMCC |
| DATE/ORDRE: | 28/05/2019 |

| | | | |
|----|------------|-----------|-----------|
| NO | DATE | OPERATION | OPERATION |
| A | 14/03/2019 | CREATION | USA |

COMMUNES DE CLAVANS
 Dossier n° : SEPTEMBRE 2019

POSTE DE RELEVAGE EAUX USEES
 DEPART RELEVAGE POMPE 2
 PUISSANCE

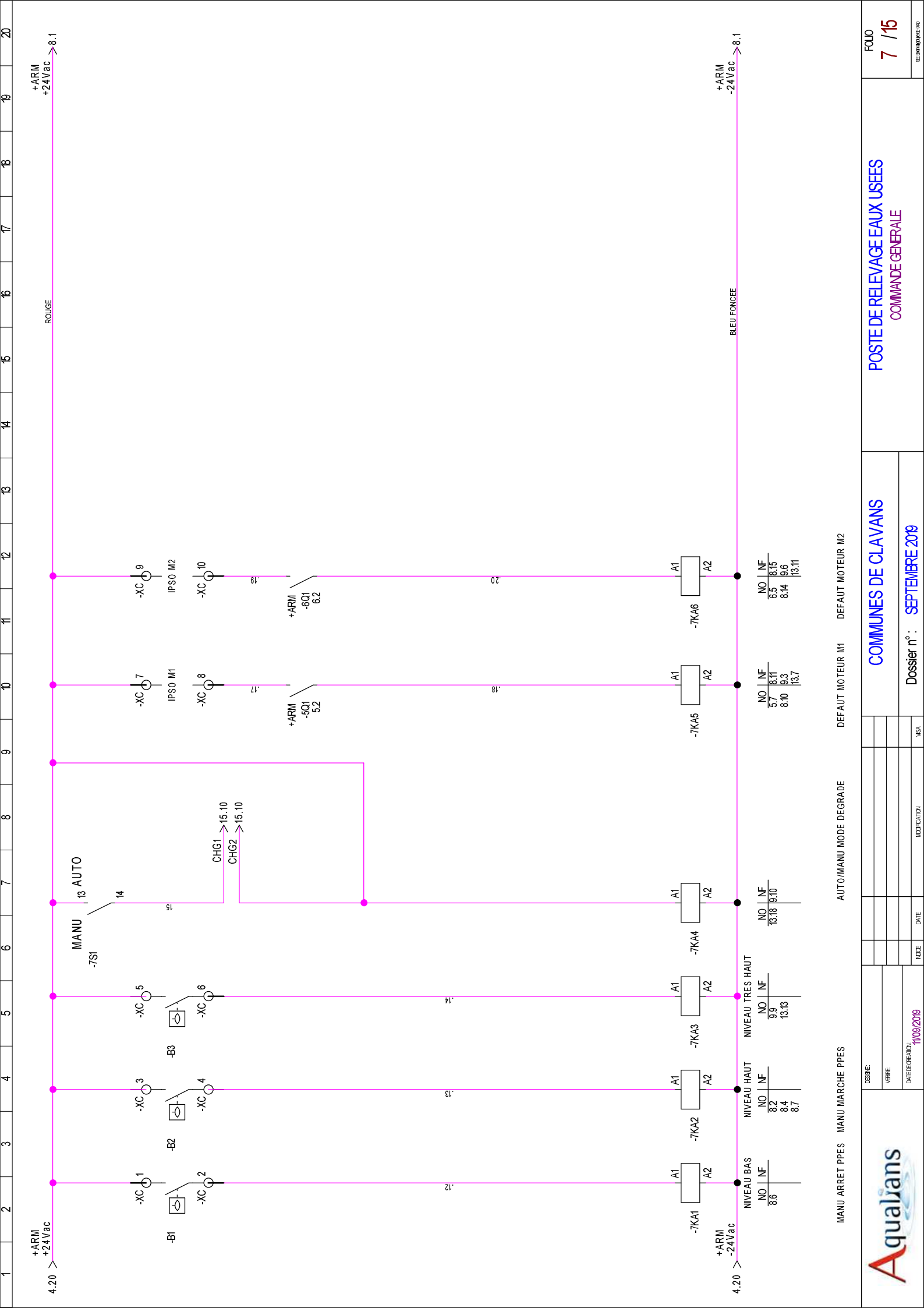

4.20 > +ARM +24Vac ROUGE > 8.1

4.20 > -ARM -24Vac BLEU FONCEE > 8.1

MANU 13 AUTO 14

-XC 9

IPSO M2

-XC 10

+ARM -6C1 6.2

-XC 7

IPSO M1

-XC 8

+ARM -5C1 5.2

CHG1 15.10

CHG2 15.10

-XC 5

-XC 6

-XC 3

-XC 4

-XC 1

-XC 2

-7KA6

-7KA5

-7KA4

-7KA3

-7KA2

-7KA1

| NO | NF |
|-------|------|
| 6.5 | 8.15 |
| 8.14 | 9.6 |
| 13.11 | |

| NO | NF |
|------|------|
| 5.7 | 8.11 |
| 8.10 | 9.3 |
| 13.7 | |

| NO | NF |
|-------|------|
| 13.18 | 9.10 |

| NO | NF |
|-----|-------|
| 9.9 | 13.13 |

| NO | NF |
|-----|-----|
| 8.2 | 8.4 |
| 8.4 | 8.7 |

| NO | NF |
|-----|----|
| 8.6 | |

MANU ARRÊT PPES MANU MARCHÉ PPES AUTO/MANU MODE DEGRADÉ DEFAULT MOTEUR M1 DEFAULT MOTEUR M2



COMMUNES DE CLAVANS

POSTE DE RELEVAGE EAUX USEES
COMMANDE GENERALE

FOLIO 7 / 15
REVISION: 01/2019

Dossier n° : SEPTEMBRE 2019

| NO | DATE | MODIFICATION | MSA |
|----|------|--------------|-----|
| | | | |
| | | | |
| | | | |

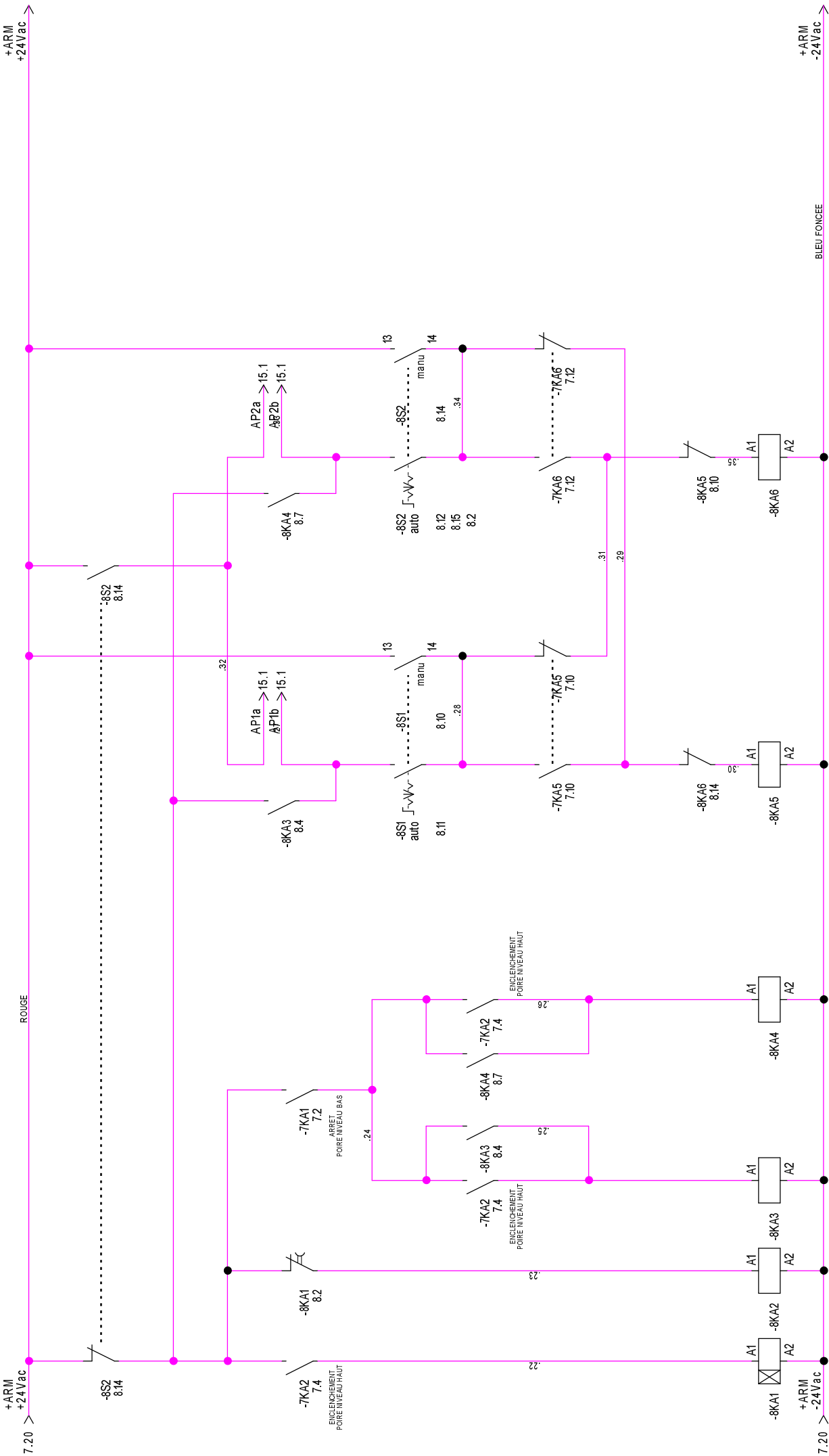

| | |
|-----|------|
| NO | NF |
| 6.6 | 8.10 |
| 9.8 | |

POMPE 2

| | |
|-----|------|
| NO | NF |
| 5.9 | 8.14 |
| 9.5 | |

POMPE 1

| | |
|------|------|
| NO | NF |
| 8.6 | 8.14 |
| 8.13 | |

POMPE 2

| | |
|-----|-----|
| NO | NF |
| 8.5 | 8.9 |
| 8.9 | |

POMPE 1

MODE DEGRADE

FRONT MONTANT TELERUPTEUR P1/P2

MODE AUTOMATIQUE

POMPE 1

POMPE 2



ESSE: /
VERIE: /
DATE DE CREATION: 11/09/2019

| | | | |
|----|------|--------------|------|
| NO | DATE | MODIFICATION | NISA |
| | | | |

COMMUNES DE CLAVANS

Dossier n°: SEPTEMBRE 2019

POSTE DE RELEVAGE EAUX USEES
COMMANDE POMPAGE

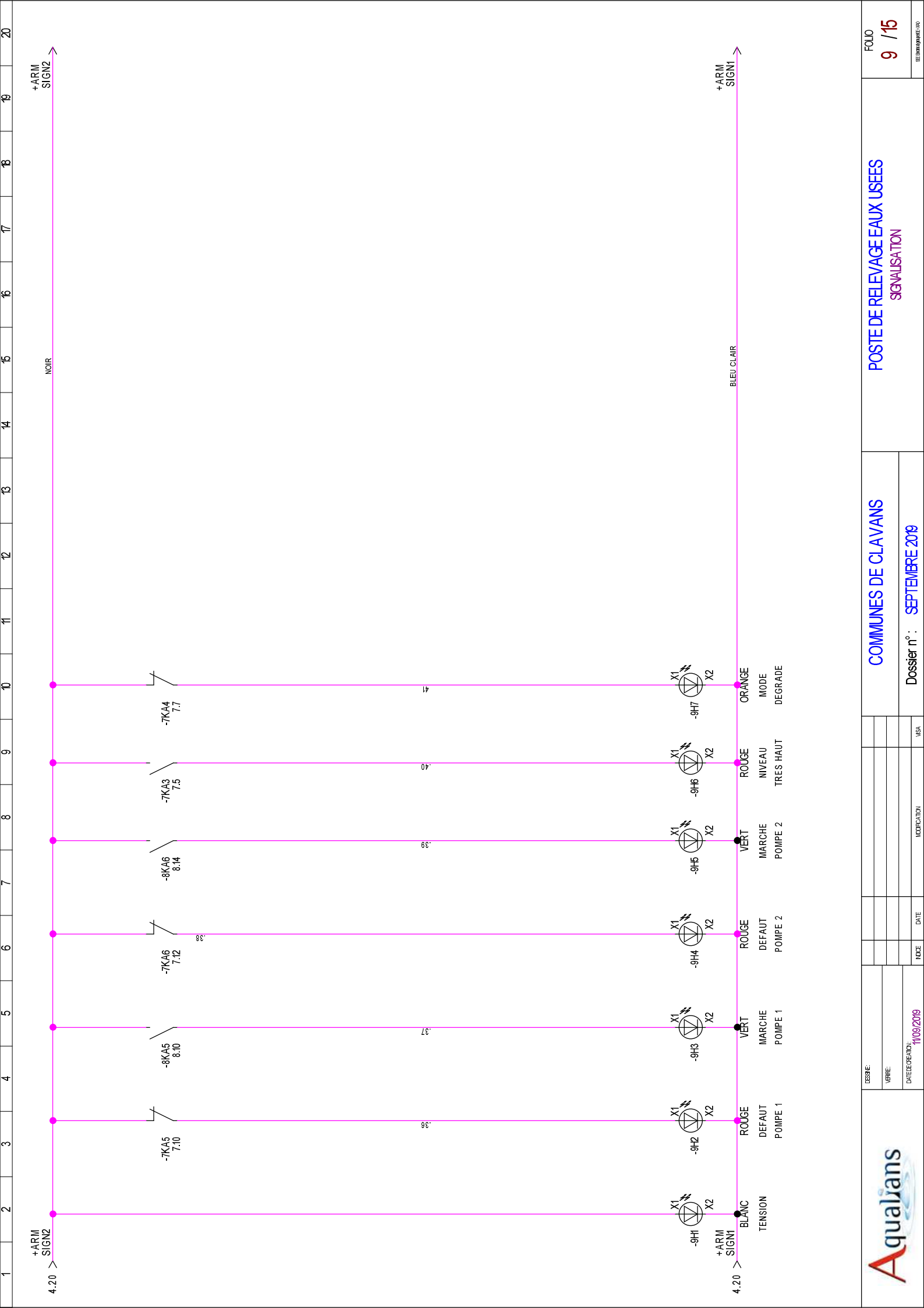

ESSEIE:
VERIFIE:
DATE DE CREATION: 11/09/2019

| | | | |
|---------|------|--------------|-----|
| NOUVEAU | DATE | MODIFICATION | MSA |
| | | | |
| | | | |
| | | | |

COMMUNES DE CLAVANS
Dossier n° : SEPTEMBRE 2019

POSTE DE RELEVAGE EAUX USEES
SIGNALISATION

1 2 3 4 5 6 7 8 9 10 11 12 13 14 15 16 17 18 19 20



ESSAI:
SERIE:
DATE DE CREATION: 11/09/2019

NOUVEAU
DATE
MODIFICATION
MSA

COMMUNES DE CLAVANS
Dossier n° : SEPTEMBRE 2019

POSTE DE RELEVAGE EAUX USEES
RESERVE

SOFREL S550 BASE ET ALIMENTATIONS





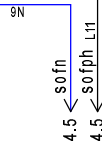
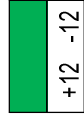

INFORMATIONS
GROUPE

0000001245.35 m3

-8A1



| | | | | | | | | | | | | | | | | | | | |
|--|---|---|---|---|---|---|---|---|----|---|----|----|----|----|----|----|----|----|----|
| 1 | 2 | 3 | 4 | 5 | 6 | 7 | 8 | 9 | 10 | 11 | 12 | 13 | 14 | 15 | 16 | 17 | 18 | 19 | 20 |
| <p style="text-align: center;">SOFREL S550 CARTE ETHERNET</p> | | | | | | | | | | | | | | | | | | | |
| <p style="text-align: center;">  </p> | | | | | | | | | | | | | | | | | | | |
| <p style="text-align: center;">  </p> | | | | | | | | | | | | | | | | | | | |
| <p style="text-align: center;">  </p> | | | | | | | | | | | | | | | | | | | |
| <p style="text-align: center;">+ARM -9A1</p> | | | | | | | | | | | | | | | | | | | |
| <p style="text-align: center;">+ARM</p> | | | | | | | | | | | | | | | | | | | |
| <p style="text-align: center;">  </p> | | | | | | | | | | | | | | | | | | | |
| <p> ESSE: .PA VERIE: JMCC DATE DE CREATION: 17/08/2019 </p> | | | | | | | | | | | | | | | | | | | |
| <p> A 11/03/2019 NOCE CREATION MODIFICATION PA USA </p> | | | | | | | | | | | | | | | | | | | |
| | | | | | | | | | | <p style="text-align: center;"> COMMUNES DE CLAVANS Dossier n° : SEPTEMBRE 2019 </p> | | | | | | | | | |
| | | | | | | | | | | <p style="text-align: center;"> POSTE DE RELEVAGE EAUX USEES CARTE GSM 3G </p> | | | | | | | | | |
| | | | | | | | | | | <p style="text-align: center;"> FOLIO 12 / 15 <small>REVISION: 01/09/2019</small> </p> | | | | | | | | | |

GRUPE DE POMPAGE N°1

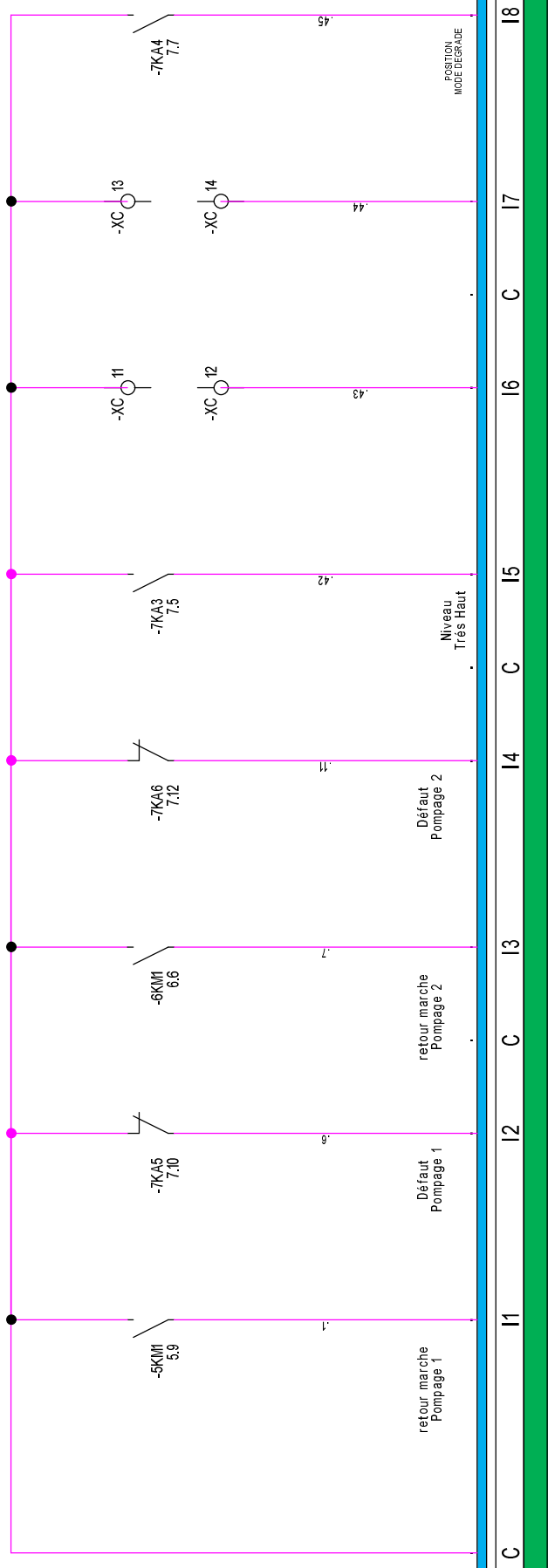

SOFREL S550 CARTE 8 DI

+ARM
-9A1

+ARM



| | |
|-------------------|------------|
| ESSE: | .PA |
| VERIE: | JMCC |
| DATE DE CREATION: | 06/05/2019 |

| | | | |
|---------|------------|-----------|-----|
| NOUVEAU | DATE | OPERATION | MSA |
| A | 11/03/2019 | CREATION | .PA |

COMMUNES DE CLAVANS
Dossier n° : SEPTEMBRE 2019

POSTE DE RELEVAGE EAUX USEES
CARTE 8DI N°2
S550

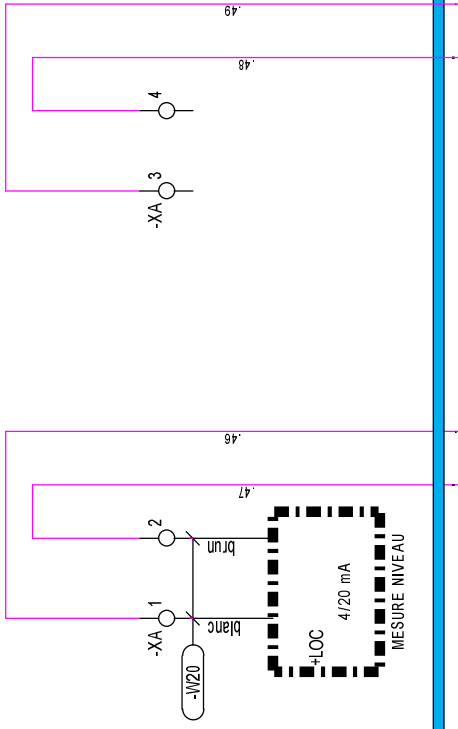

SOFREL S550 CARTE AI 4 VOIES

1A 1B 2A 2B 3A 3B 4A 4B

1 2 3 4 5 6 7 8 9 10 11 12 13 14 15 16 17 18 19 20



SOFREL S550 CARTE DO 4 VOIES

-15A1

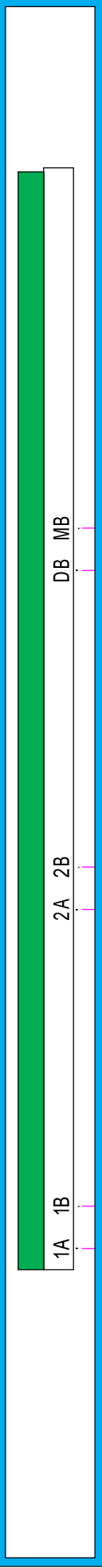

8.11 < AP1a
 8.11 < AP1b
 8.15 < AP2a
 8.15 < AP2b

7.8 < CHG1
 7.8 < CHG2
 ROUGE
 CHIEN DE GARDE

POMPAGE N°2

POMPAGE N°1

1A 1B

2A 2B

DB MB

+ARM



ESSE: PA
 VERIE: JMCC
 DATE DE CREATION: 21/05/2019

| | | | | |
|------|------------|--------------|-----|-----|
| A | 11/03/2019 | CREATION | PA | USA |
| NOCE | DATE | MODIFICATION | USA | |

COMMUNES DE CLAVANS

Dossier n° : SEPTEMBRE 2019

POSTE DE RELEVAGE EAUX USEES
 CARTE 4DO N°4
 S550

Carnet de câbles

+ARM -W1

Designation: 5G16²
 Type de câbles:
 Longueur = m

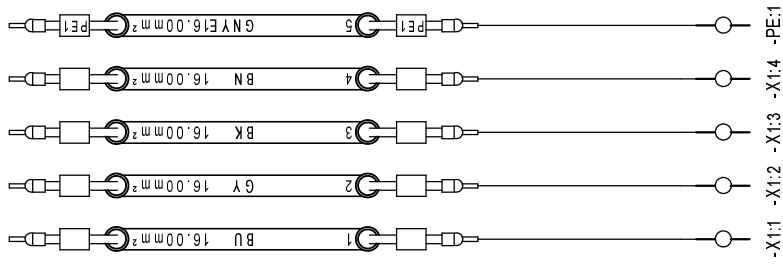

+ARM -W2

Designation: 3G1.5²
 Type de câbles:
 Longueur = m

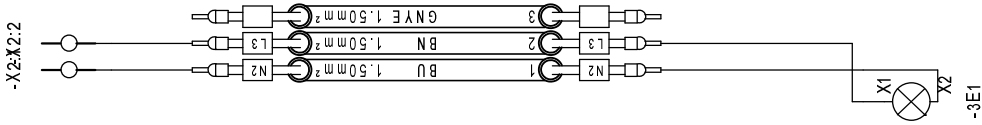

+ARM -W3

Designation: 4G2.5²
 Type de câbles:
 Longueur = m

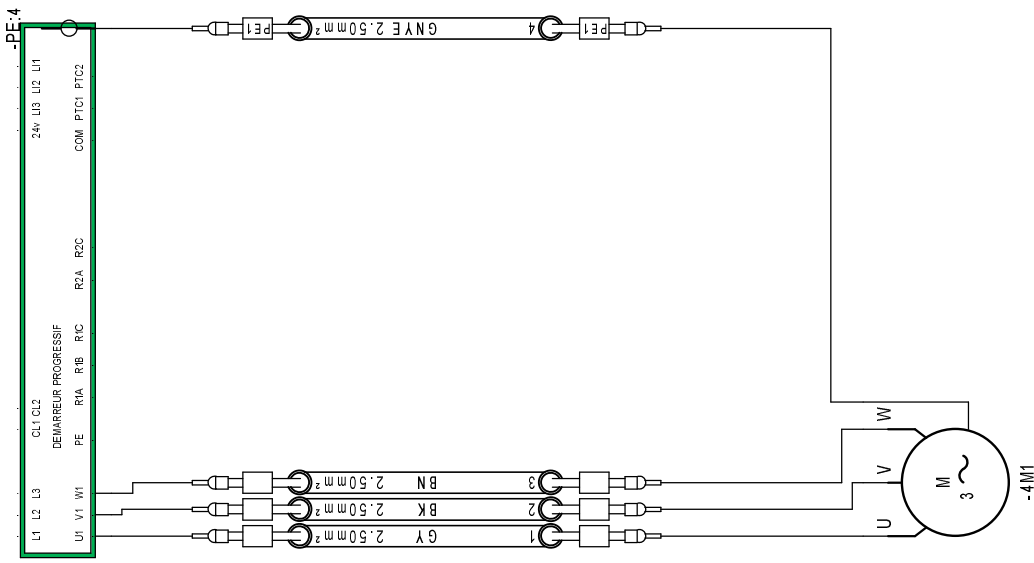

ATS22D62Q

-5ATS1

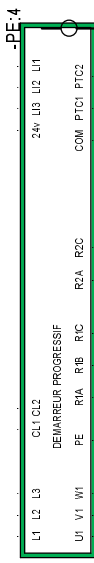

26 Kw



-4M1

ATS22D65Q

-6ATS1

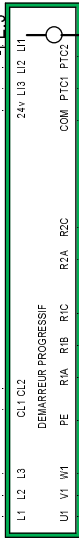

Designation: 4G2,5²
 Type de câbles: LUY-CY 2x1²
 Longueur = m

+ARM -W7

Designation: LUY-CY 2x1²
 Type de câbles: LUY-CY 2x1²
 Longueur = m

+ARM -W20

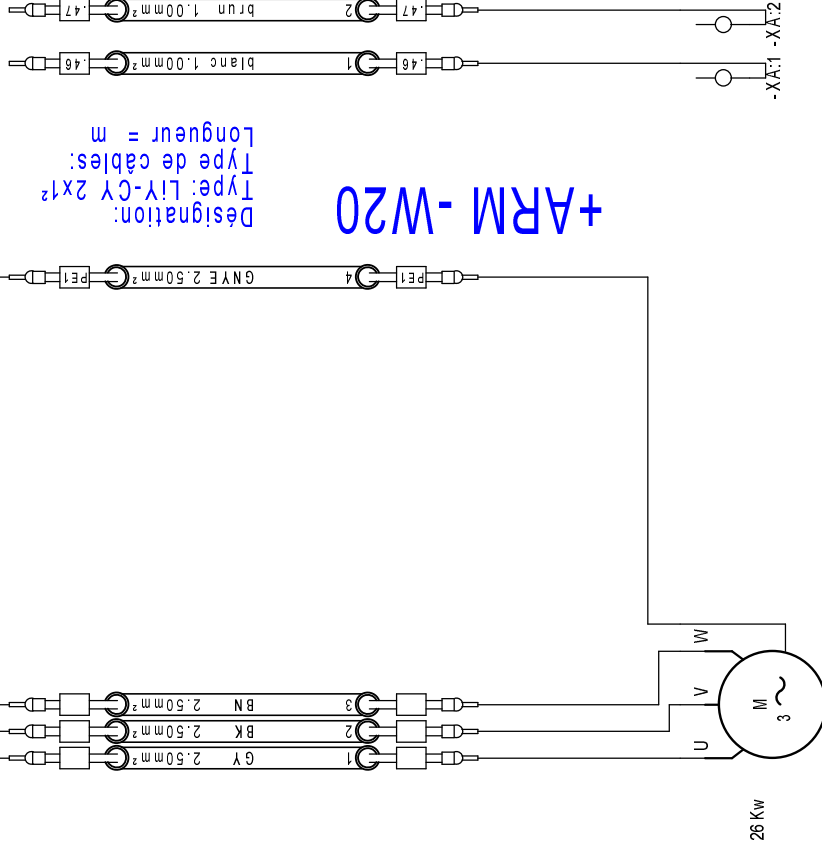

DESINE: _____
 VERIFE: _____
 DATE DE CREATION: 12/09/2019

| INDICE | DATE | MODIFICATION | VISA |
|--------|------|--------------|------|
| | | | |
| | | | |
| | | | |
| | | | |

COMMUNES DE CLAVANS
 Dossier n°: SEPTEMBRE 2019

POSTE DE RELEVAGE EAUX USEES
 -W7, -W20